



"Your Solutions Partner"

# Specifications

F.O.B. Sedalia, Missouri 65301



E303

### OPTIONS:

- 3-phase wiring
- 1000 watt elements
- Stainless steel heat compartment liner - **FMOD-SS-LINER**
- Stainless steel cutting board in lieu of poly
- Hardwood cutting board in lieu of poly
- Drop type brackets for cutting board
- Casters - **EPxxx**
- Stainless steel feet - **SS-FEET**
- Serving shelves - **656-xS/656-460-xS/956-xS/956-460-xS**
- Glass display shelves - **98x**
- Shelves/Carving boards - **441-xS/442-xS/445-xS**
- Buffet shelves - **63x/73xFL/73xBL/73xHT/83x/93xFL/83xBL/93xHT**
- Adapter plates - **31, 32, 33**
- Insets/Inset Covers - **521, 522, 523**
- Telescope covers - **546, 548**
- Tubular tray slides - **3BTS-FX-x/HD-x**
- Spillage pans - **576, 676**

### AGENCY LISTINGS:



**DUKE MANUFACTURING CO.**  
2305 N. Broadway  
St. Louis, MO 63102

800.735.3853 Toll Free  
314.231.1130 In Missouri  
314.231.5074 Fax  
www.dukemfg.com

### Approval Stamp(s):

### PROJECT INFORMATION:

PROJECT: \_\_\_\_\_  
ITEM: \_\_\_\_\_  
QUANTITY: \_\_\_\_\_

### MODEL:

## AeroHot Steamtables Hot Food Units - Electric

- E302** 2 top openings
- E303** 3 top openings
- E304** 4 top openings
- E305** 5 top openings

### TOP:

- 20 gauge, 300 Series stainless steel
- Die-stamped openings - 12" x 20"
- Poly carving board - 7"W x 1/2" thick with 18 gauge stainless steel support base and die-stamped brackets

### HEAT COMPARTMENTS:

- Each with die-formed 8" deep galvanized liner
- Insulated with 1" thick fiberglass or equal, all four sides and bottom
- Single phase standard

### BODY, UNDERSHELF AND LEGS:

- 20 gauge, 430 Series stainless steel body
- 18 gauge, 430 Series stainless steel undershelf
- 430 Series stainless steel tubular legs with adjustable plastic feet

### ELECTRICAL INFORMATION:

- 500 or 750 watt dome-type element for each compartment
- Wired to operate on 120, 208 or 240 volt
- Single or three phase
- AC current
- Each section with infinite switch
- Permanently wired, 6' long cord with plug provided

### SHORT FORM SPECIFICATIONS:

**Duke AeroHot Steamtables - Hot Food - Electric.** Top shall be 20 gauge, 300 Series stainless steel, with body, undershelf and legs formed of heavy gauge 430 Series stainless steel. Top to have die-stamped openings measuring 12-1/16" x 20-1/16", with 8" deep galvanized liner. Each compartment to be insulated on all four sides and bottom with 1" thick fiberglass or equal, having thermal conductivity of 0.27 or less, with single phase standard. Each compartment to have 500 or 750 watt dome-type element fitted inside, above warming compartment. Wired to operate on 120, 208 or 240 volt, single or 3-phase. AC current, as ordered. Each section to be controlled by infinite switch. Permanently wired, 6' long cord with plug provided. Units to be furnished with poly carbonate carving board measuring 7" x 1/2" thick with 18 gauge stainless steel support base and die-stamped brackets. Portable units to have NSF listed casters, 5" diameter, rubber, swivel-type, two with locks, all non-marking tires, with 9"L pusher bar attached to end panel on operator's right.

"P" - prefix on model number denotes portable unit.

# Aerohot®

## AEROHOT STEAMTABLES HOT FOOD UNITS - ELECTRIC

- E302** 2 top openings
- E303** 3 top openings
- E304** 4 top openings
- E305** 5 top openings

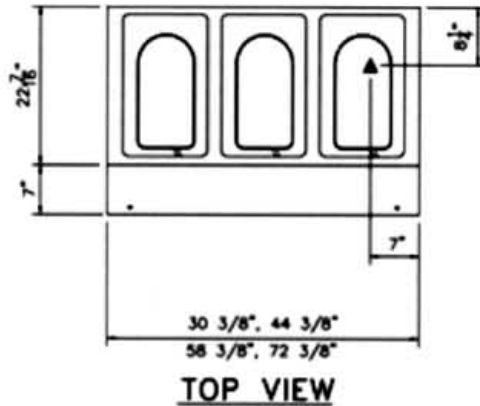

LEGEND	
▲	ELECTRICAL CONNECTION
"P" = prefix on model number denotes portable unit	

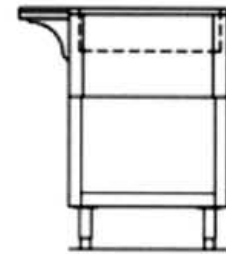
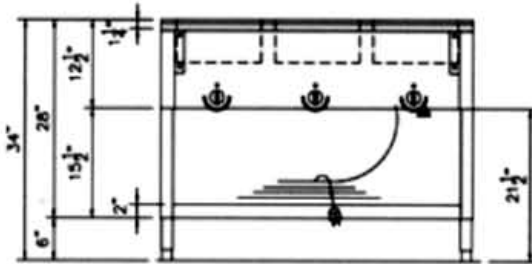

### DIMENSIONS:

Freight Class: 85

Model	Length		Width		Height		Top Openings	Cube ft. crated	Weight	
	in.	cm	in.	cm	in.	cm			lbs.	kg
<b>E302/EP302</b>	30-3/8	77.2	22-7/16	57.1	34	86.4	2	23.4	81/90	36.8/40.9
<b>E303/EP303</b>	44-3/8	112.8	22-7/16	57.1	34	86.4	3	32.5	107/114	48.6/51.8
<b>E304/EP304</b>	58-3/8	148.3	22-7/16	57.1	34	86.4	4	41.5	138/144	62.7/65.5
<b>E305/EP305</b>	72-3/8	183.9	22-7/16	57.1	34	86.4	5	50.5	165/172	75.0/78.2

### ELECTRICAL SPECIFICATIONS:

Model	120 Volt - 500 watt elements			208 Volt - 750 watt elements			240 Volt - 750 watt elements		
	Watts	Amps	NEMA	Watts	Amps	NEMA	Watts	Amps	NEMA
<b>E302/EP302</b>	1000	8.3	5-15	1500	7.2	6-20	1500	6.3	6-20
<b>E303/EP303</b>	1500	12.5	5-15	2250	10.8	6-20	2250	9.4	6-20
<b>E304/EP304</b>	2000	16.7	L5-30	3000	14.4	6-20	3000	12.5	6-20
<b>E305/EP305</b>	2500	20.8	L5-30	3750	18.0	L6-30	3750	15.6	6-20

Cord and NEMA plug included.



**DUKE MANUFACTURING CO.**  
2305 N. Broadway  
St. Louis, MO 63102

800.735.3853 Toll Free  
314.231.1130 In Missouri  
314.231.5074 Fax  
[www.dukemfg.com](http://www.dukemfg.com)

"Your Solutions Partner"

03/03

Specifications subject to change

Printed in U.S.A.  
©2003, Duke Manufacturing Co.