

HOBART701 S Ridge Avenue, Troy, OH 45374
1-888-4HOBART • www.hobartcorp.com**THE EDGE12
SLICER****HOBART****STANDARD FEATURES**

- 1-Speed, 1/2 H.P. Knife Drive Motor
- Poly-V Belt Drive System
- 45° Product Table
- Sanitary Anodized Aluminum Base
- Anodized Aluminum Carriage and Knife Cover
- No-Volt Release
- Removable Carriage System
- 12" Diameter Chrome-Plated Carbon Steel Knife
- Removable Top-Mounted Ceramic Simultaneous Sharpener
- Permanent Knife Ring Guard
- Removable Product Deflector
- Rear-Mounted Removable Meat Grip with Contoured Handle

MODEL

- The EDGE12 Slicer – 120/60/1**
Manual Slicer and 12" Knife Diameter

Specifications, Details and Dimensions on Inside and Back.

**THE EDGE12 SLICER**

THE EDGE12 SLICER



701 S Ridge Avenue, Troy, OH 45374
1-888-4HOBART • www.hobartcorp.com

SOLUTIONS / BENEFITS

1-Speed, ½ H.P. Knife Drive Motor

Durability and performance

Poly V-Belt Drive System

Performance, durability, reduced maintenance

- Design extends belt life while producing optimal slicing results
- Quieter operating slicer
- More economical for service and repairs with reduced parts and reduced service time

Full Gravity Feed

Full 45° angle feed requires less mechanical pressure.

Sanitary Anodized Aluminum Base

Improved sanitation, labor savings

- One piece base makes cleaning easy
- No cracks/crevices or bolt holes where product can lodge and bacteria may grow
- Easy cleaning and durable finish

Anodized Aluminum Carriage and Knife Cover

Improved sanitation, durability

- Maximum sanitation and minimal cleanup time
- Corrosion resistant, impact resistant

No-Volt Release

- Slicer must be restarted if power fails or slicer is unplugged

Removable Carriage System

Improves Sanitation

- Removable for complete cleaning and sanitation procedures

12" Diameter Chrome-Plated Carbon Steel Knife

Reduced cost of ownership, improved yield

- Thin edge design improves yield

Top Mounted Ceramic Stone Sharpener

Ease of use, improved sanitation

- Single action sharpens and hones in 15 seconds
- Removable and submersible for easy cleaning and sanitation

Permanently Mounted Ring Guard

Protection

- Protects knife during operation and cleaning

Removable Rear Deflector

Improved sanitation, ease of use

- Allows access for thorough cleaning
- No tools required means easy removal during cleaning

Removable Meat Grip

Ease of cleaning and use

- Removable meat grip allows for easy cleaning and meat grip extension ensures oversized loaves are secured



701 S Ridge Avenue, Troy, OH 45374
1-888-4HOBART • www.hobartcorp.com

THE EDGE12 SLICER

SPECIFICATIONS

KNIFE MOTOR: 1-speed, ½ H.P. Totally enclosed, permanently lubricated ball bearings. Single phase capacitor-start, induction run.

ELECTRICAL SPECIFICATIONS: 120/60/1 ETL Listed, 4 Amp.

POLY V BELT DRIVE SYSTEM: Knife is driven by a Poly V-belt and runs at 300 rpm for optimal performance. Aluminum knife shaft pulley and steel motor pulley.

FULL GRAVITY FEED: Full 45° angle feed requires less mechanical pressure.

SANITARY ANODIZED ALUMINUM BASE: One-piece base makes cleaning easy. Surfaces are durable and smooth presenting no holes or crevices in which food can lodge. Easy clean-up and durable finish to withstand harsh cleaning products.

NO-VOLT RELEASE: In the event of a power loss, slicer must be restarted before operation can continue.

REMOVABLE CARRIAGE SYSTEM: Anodized aluminum carriage system is removable for thorough cleaning and sanitation. The carriage has 11.5" manual travel.

CHROME-PLATED CARBON STEEL KNIFE: 12" diameter, hollow ground, hardened, polished, forged and chromium-plated carbon steel knife. Anodized aluminum knife cover provides easy cleaning access. Gauge plate protects knife edge when index knob is turned to full clockwise position.

CUTTING CAPACITY: Carriage handles food up to 10.0" wide by 6.0" high or 8.0" diameter.

SLICE THICKNESS: Precision system provides infinite slice adjustment and consistent cuts of hard or soft foods from tissue thin to ⅛" (14 mm).

TOP MOUNTED CERAMIC STONE SHARPENER: Built-in, top-mounted, two stone dual-action system for a consistently sharp knife edge. Unit is removable for easy cleaning.

PERMANENTLY MOUNTED RING GUARD: Protects knife edge during operation and cleaning.

REMOVABLE PRODUCT DEFLECTOR: Allows for thorough cleaning of slicer.

FINISH: Anodized aluminum carriage, gauge plate, knife cover and base.

REMOVABLE MEAT GRIP: Removable meat grip allows for easy cleaning and meat grip extension ensures oversized loaves are secured.

START/STOP BUTTON: Simple START/STOP button.

CORD AND PLUG: Attached 6-foot, flexible 3-wire cord and plug for grounded receptacle.

WARRANTY: All parts, service and travel coverage for one year excluding wear items.

WEIGHT: Shipping – 85 lbs.; Net – 68 lbs.

THE EDGE12 SLICER



701 S Ridge Avenue, Troy, OH 45374
1-888-4HOBART • www.hobartcorp.com

DETAILS AND DIMENSIONS

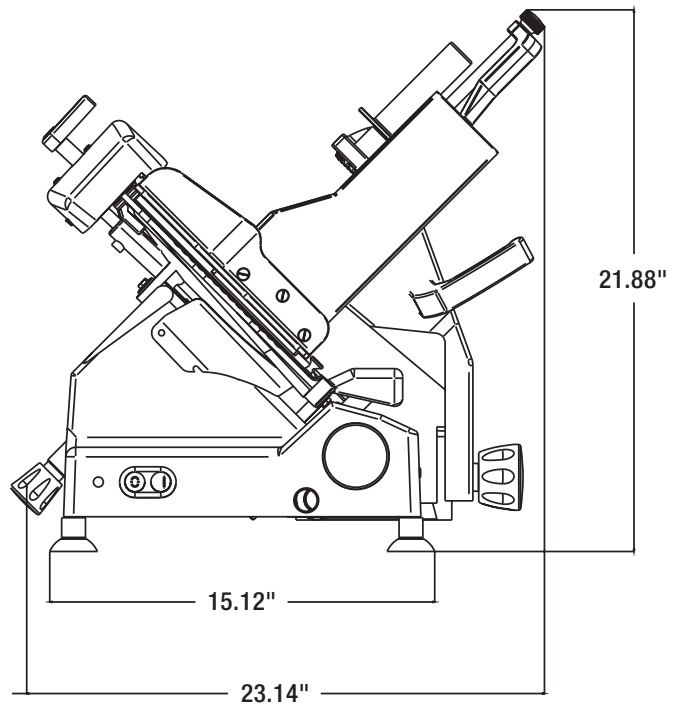
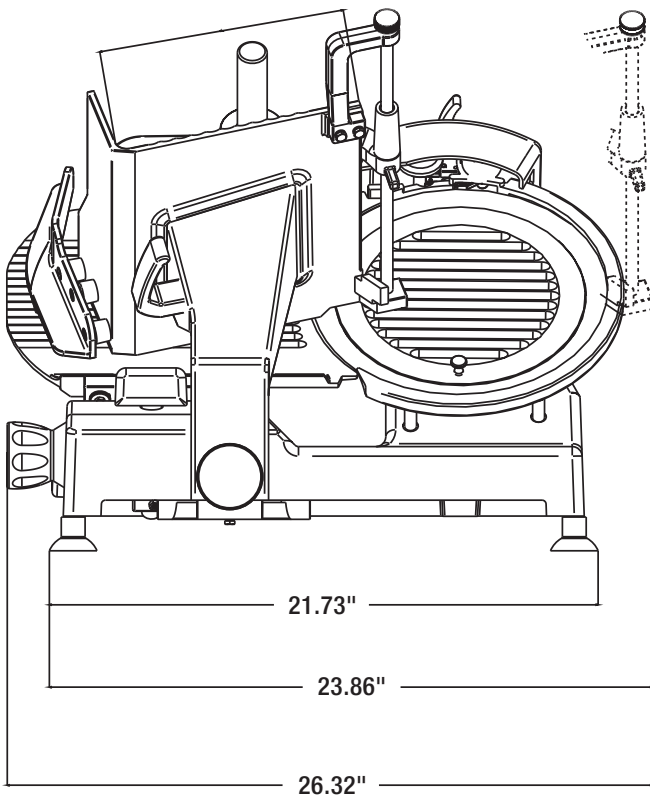

As continued product improvement is a policy of Hobart, specifications are subject to change without notice.