

S-Series 450 Ice Cube Machine



S-Series 450
Ice Machine on B-400 Bin

-
- SANITATION**
We've made it simple to clean
 - SAVINGS**
The perfect balance of power and efficiency
 - SOUND**
Designed to run whisper-quiet
 - SERVICEABILITY**
Easy access means less downtime
-

- Up to 460 lbs. (209 kgs.) daily ice production
- Up to CEE Tier 2 energy and water efficiency rating
- Only 30" (76.20 cm) wide
- Removable water distribution tube with no tools
- Food zone designed with soft, round, cove corners
- Patented cleaning and sanitizing technology
- Select components made with AlphaSan® antimicrobial

- Hinged front door for easy access
- Warranty
 - 5-year parts and 5-year labor coverage on ice machine evaporator
 - 5-year parts and 3-year labor coverage on ice machine compressor
 - 3-year parts-and-labor coverage on all other ice machine, dispenser, and storage bin components



ISO 9001:2000
Quality System
Certified

America's #1 Selling Ice Machine
Ice Cube & Flake Machines • Ice Storage Bins • Ice Dispensers



Manitowoc S-Series 450

Model	Ice Shape	Ice Production 24 hours				Power kWh/100 lbs.	CEE* Rating
		70°/50°		90°/70°			
		lbs.	kgs.	lbs.	kgs.		
SY-0454A	half-dice	460	209	365	166	6.3	Tier 2
SY-0455W	half-dice	465	211	400	181	5.1	Tier 1
SD-0452A	dice	455	206	345	157	6.6	Tier 1
SD-0453W	dice	435	197	385	175	5.1	Tier 1

Water usage/100 lbs./45.4 kgs. of Ice
Potable Water: 18 gallons, 68 liters • Water-cooled Condenser: 153 gallons, 579 liters

Order ice storage bin separately. "A" or "W" following model number indicates "Air" or "Water" condensing unit.

Consortium for Energy Efficiency (CEE) is a North American nonprofit organization that promotes energy-efficient products, technologies and services; also the principal entity for the development of ice maker efficiency standards.



Certified in Accordance with ARI Automatic Commercial Ice-Cube Machines (Batch-Type) Certification Program, which is based on ARI Standard 810

Ice Machine Electric

115/60/1 standard. (208-230/60/1 and 230/50/1 also available.)

Min. circuit ampacity: Air-cooled: 13.6 amps
Water-cooled: 12.9 amps

Max. fuse size: Air-cooled, Water-cooled: 20 amps

HACR-type circuit breakers can be used in place of fuses.

Specifications

BTU Per Hour:
7,000 (average) 9,600 (peak)

Compressor:
Nominal rating: 3/4 HP

Cupra-Nickel Condenser:
(Water-cooled models)

Adds protection from corrosive water elements.

Operating Limits:

- Ambient Temperature Range:**
Air and water:
35° to 110°F (1.6° to 43.3°C)
Remote: -20° to 120°F (-29° to 49°C)

- Water Temperature Range:**
35° to 90°F (1.6° to 32.2°C)

- Water Pressure Ice Maker Water In:**
Min. 20 psi (137.9 kPa)
Max. 80 psi (551.1 kPa)

- Condenser Inlet Water In:**
(Water-cooled only)
Min. 20 psi (137.9 kPa)
Max. 150 psi (1,034.2 kPa)

Air Flow Top View

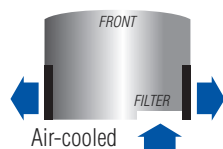

AuCS® SI Accessory



Automatic Cleaning System purchased factory installed in the machine or as an option for field retrofit.

2 Cube Sizes Available



Half Dice
3/8" x 1 1/8" x 7/8"
(.95 x 2.86 x 2.22 cm)



Dice
7/8" x 7/8" x 7/8"
(2.22 x 2.22 x 2.22 cm)

Space-Saving Designs



	S-450 B-400	S-450 B-570
Height	59.50" 151.13 cm	71.50" 181.61 cm
Width	30.00" 76.20 cm	30.00" 76.20 cm
Depth	34.00" 86.30 cm	34.00" 86.30 cm
Bin Storage	290 lbs. 131.7 kgs.	430 lbs. 195.2 kgs.

Height includes adjustable bin legs 6.00" to 8.00", (15.24 to 20.32 cm) set at 6.00" (15.24 cm). For comparison purposes multiply ARI capacity by 1.3 (30%) to arrive at approximate "Application Rating Capacity."

24-HOUR PRODUCTION†								lbs. kgs.
HALF-DICE CUBE				DICE CUBE				
air temp		water temp		air temp		water temp		
°F	50°	70°	90°	°F	50°	70°	90°	
°C	10°	21°	32°	°C	10°	21°	32°	
AIR-COOLED	70°	460	430	395	70°	455	420	380
	21°	209	195	179	21°	206	191	172
	80°	425	395	365	80°	420	385	350
	27°	193	179	166	27°	191	175	159
	90°	390	365	335	90°	380	345	325
32°	177	166	152	32°	172	157	147	
WATER-COOLED	70°	465	420	375	70°	435	395	355
	21°	211	191	170	21°	197	179	161
	80°	455	410	370	80°	430	390	350
	27°	206	186	168	27°	195	177	159
	90°	445	400	365	90°	425	385	345
32°	202	181	166	32°	193	175	157	

†Data is published for 60 Hz machines. 50 Hz machines produce approximately 7% less ice.

S-450 on B-400 Storage Bin

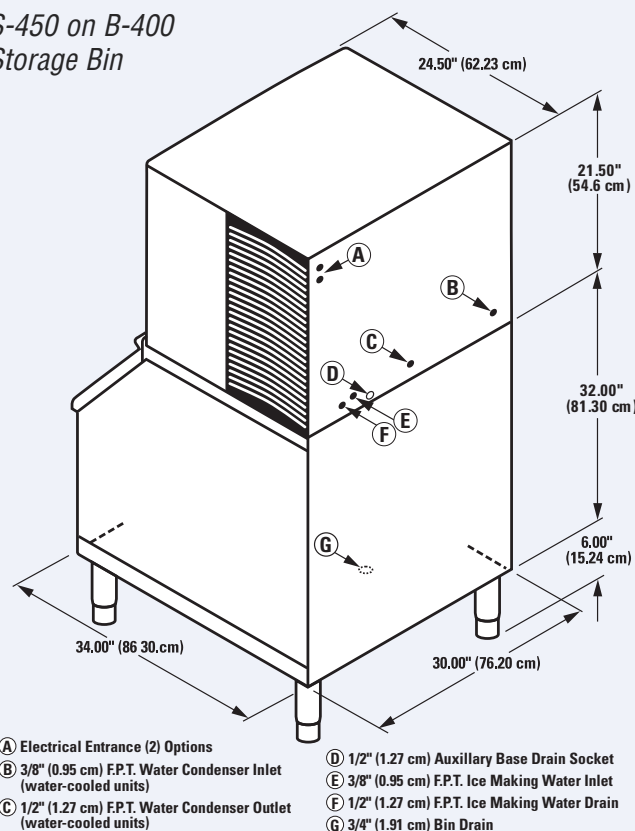

Installation Note -

Minimum installation clearance— Top/sides: 8" (20.32 cm); Back: 5" (12.7 cm).



MANITOWOC ICE
2110 South 26th Street, P.O. Box 1720
Manitowoc, WI 54221-1720, USA
Ph: 920-682-0161 • Fax: 920-683-7589
Visit us online at www.manitowocice.com



©2009 Manitowoc. 909 Continuing product improvement may necessitate change of specifications without notice. 2987D